

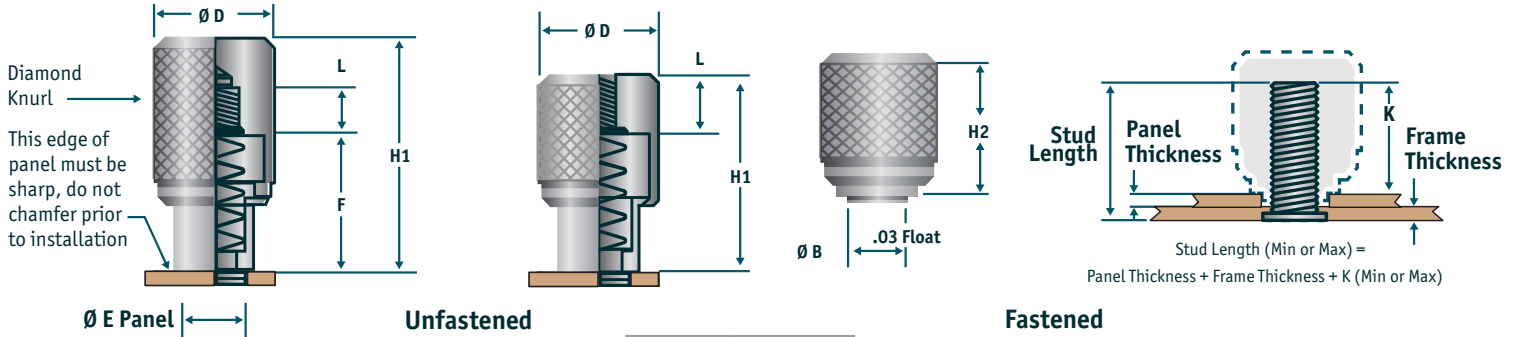

### Retractable Captive Nut

Matdan MN series retractable captive nuts are ideal for applications when you need to easily attach a panel to threaded studs. Quickly install the fastener by hand using the oversized knurled knob.



E - Installation Hole

Thread Size	Knob Style	D	L	F	H1	H2	B	Metric	Unified	K Min	K Max
4-40 / M3	Through (T)	0.42	0.14	-	0.50	0.37	0.217	5.6 +.03/-05	0.219 +.003/-000	0.28	0.37
	Blind (B)		0.16	0.36	0.66	0.52					
6-32 / M3.5	Through (T)	0.45	0.19	-	0.70	0.49	0.248	6.4 +.03/-05	0.250 +.003/-000	0.4	0.47
	Blind (B)		0.21	0.51	0.91	0.70					
8-32 / M4	Through (T)	0.51	0.18	-	0.70	0.49	0.310	8 +.00/-08	0.312 +.003/-000	0.4	0.52
	Blind (B)		0.21	0.52	0.91	0.70					
10-32 / M5	Through (T)	0.58	0.18	-	0.70	0.49	0.372	9.5 +.10/-00	0.375 +.003/-000	0.5	0.65
	Blind (B)		0.21	0.52	0.91	0.70					
1/4-20 / M6	Through (T)	0.58	0.25	-	0.90	0.63	0.372	9.5 +.10/-00	0.375 +.003/-000	0.5	0.65
	Blind (B)		0.28	0.65	1.16	0.91					

#### Installation Notes:

1. Panel Thickness MIN .036"
2. Total Float .031"
3. MIN distance from panel edge is 1.5 X OE
4. Panel Installation Materials: Aluminum, Low Carbon Steel, and Annealed Stainless Steel
5. Backup Tool Required

#### Material & Finish:

- Knob: 6000 Series Aluminum
- Ferrule: Carbon Steel, Heat Treated, Zinc Plated, Chromate Plus
- Spring: 300 Series Stainless Steel black, powder coat

### Part Number Callout

Series Code	Captivation Code		Thread Code				Head Style		Ferrule Length Code	Finish Code	
MN	P	Press-In	04	4-40	M3	3mm	T	Through	1*	N	Natural
	F	Flare-In	06	6-32	35	3.5mm	B	Blind		B	Black
	L	Floating	08	8-32	M4	4mm					
	B	PC Board	10	10-32	M5	5mm					
			14	1/4-20	M6	6mm					

\* Other Options Available for Flare-In or Floating. Available upon Request.